



Taco HC 4502B – HC 3502B



Electro-hydraulic two post lifts.

Realignment of the two carriages using metal cables that guarantee excellent synchronisation.
Three-stages asymmetrical lifting arms.



Sollevatori elettroidraulici a due colonne.

Riallineamento dei due carrelli tramite funi metalliche che garantiscono un'ottima sincronizzazione dei carrelli. Bracci asimmetrici a tre stadi.

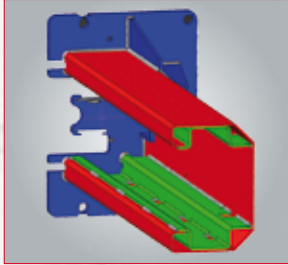

- Internally reinforced column structure.
Struttura colonna rinforzata internamente

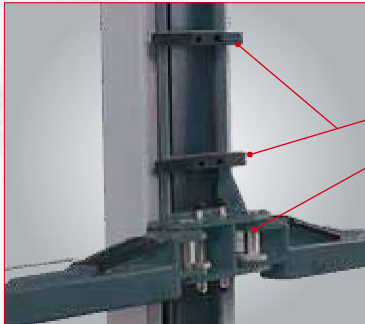

- Rubber door protections.
Protezioni in gomma salvaportiera
- Toothed sector arm rotation stop system.
Arresto rotazione bracci a settori dentati



- Double threaded to ensure excellent vertical adjustment (95÷180 mm).
Doppia filettatura per una grande regolazione verticale del tampone (95÷180 mm)



- 4 three-section support arms.
4 bracci a 3 stadi





DIMENSIONS - DIMENSIONI

TECO HC4502 B - TECO HC3502 B

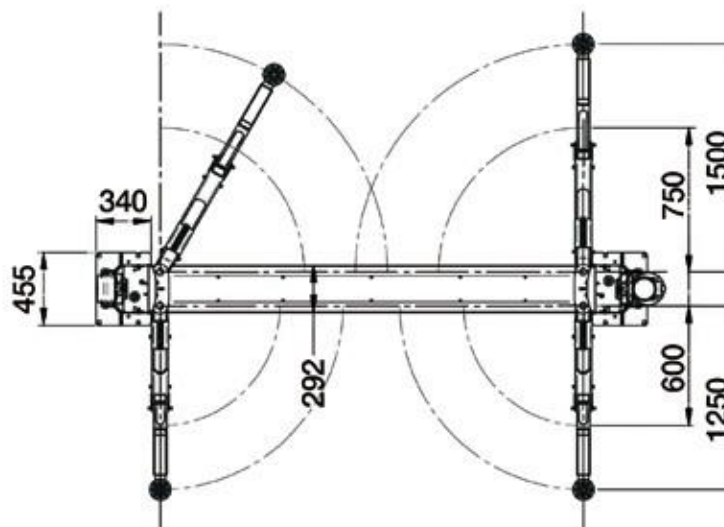
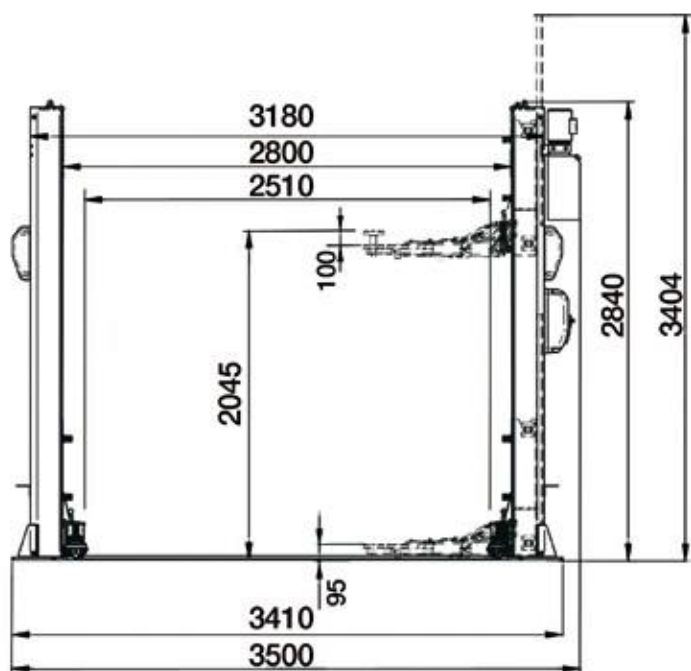

All models supplied with:

- ✓ Mechanical carriage support device on each column ensures optimum working safety.
- ✓ Two set of extension pads.

Tutti modelli completi di:

- ✓ Dispositivo di appoggio meccanico dei carrelli su ogni colonna che garantisce la massima sicurezza di lavoro.
- ✓ Due set di prolunghe tamponi.

OPTIONAL ACCESSORIES

- Set of masonry bolts (compulsory)
- Emergency hand pump.
- Load-bearing base frame

ACCESSORI A RICHIESTA

- Set tasselli di fissaggio al suolo (obbligatorio)
- Pompa manuale di emergenza
- Basamento portante

TECHNICAL DATA

DATI TECNICI

TECO HC4502 B

TECO HC3502 B

Lift capacity	Portata sollevatore	4500 kg	3500 kg
Lifting time	Tempo di salita	40 s	
Three phase motor	Motore trifase	400/230V - 3kW - 3Ph - 50/60Hz	
Single phase motor	Motore monofase	230V - 3kW - 1Ph - 50/60Hz	
Max. lifting height	Altezza max. di sollevamento	1945 mm	
Lift minimum height	Altezza minima sollevatore	95 mm	